



# ANALOG DEVICES 500 kSPS, Software Selectable True Bipolar Input, 2-Channel, 12-Bit Plus Sign SAR ADC

Preliminary Technical Data

AD7321\*

## FEATURES

- 12-Bit Plus Sign SAR ADC
- True Bipolar Analog Inputs
- Software Selectable Input Ranges  
± 10V, ± 5V, ± 2.5V, 0 to 10V
- Two Analog Inputs with Channel Sequencer
- Single Ended, True Differential and Pseudo Differential Capability.
- High Analog Input Impedance
- Low Power: 12 mW
- Full Power Signal Bandwidth: 22 MHz
- Internal 2.5 V Reference
- High Speed Serial Interface
- Power Down Modes
- 14-Lead TSSOP
- iCMOS™ Process Technology

## GENERAL DESCRIPTION

The AD7321 is a 2-Channel, 12-Bit plus Sign Successive Approximation ADC. The ADC has a high speed serial interface that can operate at throughput rates up to 500 ksp/s.

The AD7321 can accept true bipolar Analog Input signals. The AD7321 has four software selectable inputs Ranges, ±10V, ±5V, ±2.5V and 0 to 10V. Each analog input channel can be independently programmed to one of the four input ranges.

The Analog input channels on the AD7321 can be programmed to be Single-Ended, true Differential or Pseudo Differential.

The AD7321 contains a 2.5V Internal reference. The AD7321 also allows for external Reference operation. If a 3V reference is applied the REF<sub>IN/OUT</sub> pin the AD7321 can accept a true Bipolar ±12V Analog Input. Minimum V<sub>DD</sub> and V<sub>SS</sub> supplies of ±12V are required for the ±12V Input Range.

## FUNCTIONAL BLOCK DIAGRAM

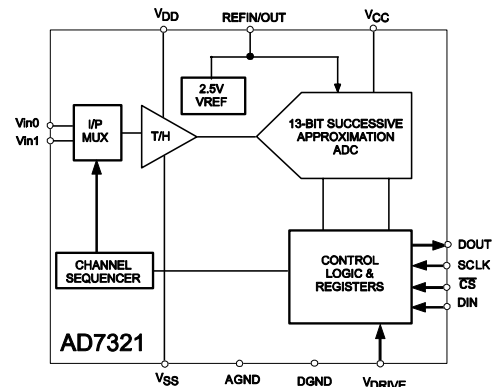

Figure 1.

## PRODUCT HIGHLIGHTS

1. The AD7321 can accept True Bipolar Analog Input signals, ±10V, ±5V, ±2.5V and 0 to 10V unipolar signals.
2. The Two Analog Inputs can be configured as Two Single-Ended inputs, One True Differential or One Pseudo Differential Input. The AD7321 has high Impedance Analog Inputs.
3. High Speed Serial Interface. SPI/QSPI/DSP/MICROWIRE Compatible. Throughput Rates up to 500 ksp/s can be achieved.
4. Low Power, 26 mW at maximum throughput rate of 500 ksp/s.

Table 1. Related Products

Device Number	Throughput Rate - ksp/s	Number of bits	Number of Channels
AD7328	1000	12 bit + Sign	8
AD7327	500	12 bit + Sign	8
AD7324	1000	12 bit + Sign	4
AD7323	500	12 bit + Sign	4
AD7322	1000	12 bit + Sign	2

\* Protected by U.S. Patent No. 6,731,232

### iCMOS™ Process Technology

For analog systems designers within industrial/instrumentation equipment OEMs who need high performance ICs at higher-voltage levels, iCMOS is a technology platform that enables the development of analog ICs capable of 30V and operating at +/- 15V supplies while allowing dramatic reductions in power consumption and package size, and increased AC and DC performance.

### Rev. PrB

Information furnished by Analog Devices is believed to be accurate and reliable. However, no responsibility is assumed by Analog Devices for its use, nor for any infringements of patents or other rights of third parties that may result from its use. Specifications subject to change without notice. No license is granted by implication or otherwise under any patent or patent rights of Analog Devices. Trademarks and registered trademarks are the property of their respective companies.

One Technology Way, P.O. Box 9106, Norwood, MA 02062-9106, U.S.A.  
Tel: 781.329.4700 www.analog.com  
Fax: 781.326.8703 © 2005 Analog Devices, Inc. All rights reserved.

**TABLE OF CONTENTS**

AD7321—Specifications.....	3	Theory of Operation.....	9
Absolute Maximum Ratings.....	6	AD7321 Registers.....	12
Pin Functional Descriptions .....	7	Serial interface .....	17
Terminology .....	8	OUTLINE DIMENSIONS.....	18

**REVISION HISTORY**

Revision PrB: Preliminary Version

AD7321—SPECIFICATIONS<sup>1</sup>Table 2. Unless otherwise noted,  $V_{DD} = +12V$  to  $+16.5V$ ,  $V_{SS} = -12V$  to  $-16.5V$ ,  $V_{CC} = 2.7V$  to  $5.25V$ ,  $V_{DRIVE} = 2.7V$  to  $5.25V$ ,  $V_{REF} = 2.5V$  Internal/External,  $f_{SCLK} = 10$  MHz,  $f_S = 500$  ksp/s  $T_A = T_{MAX}$  to  $T_{MIN}$ 

Parameter	Specification	Units	Test Conditions/Comments
<b>DYNAMIC PERFORMANCE</b>			
Signal to Noise Ratio (SNR) <sup>2</sup>	76	dB min	$F_{IN} = 50$ kHz Sine Wave Differential Mode
	73	dB min	Single-Ended /Pseudo Differential Mode
Signal to Noise + Distortion (SINAD) <sup>2</sup>	75	dB min	Differential Mode
	72	dB min	Single-Ended/Pseudo Differential Mode
Total Harmonic Distortion (THD) <sup>2</sup>	-75	dB max	-83 dB typ
Peak Harmonic or Spurious Noise (SFDR) <sup>2</sup>	-80	dB max	
Intermodulation Distortion (IMD) <sup>2</sup>			$F_a = 40.1$ kHz, $F_b = 41.5$ kHz
Second Order Terms	-88	dB typ	
Third Order Terms	-88	dB typ	
Aperature Delay <sup>2</sup>	10	ns max	
Aperature Jitter <sup>2</sup>	50	ps typ	
Common Mode Rejection (CMRR) <sup>2</sup>	TBD	dB typ	
Channel-to-Channel Isolation <sup>2</sup>	-70	dB typ	See Terminology
Full Power Bandwidth <sup>2</sup>	22	MHz typ	@ 3 dB
	4.5	MHz typ	@ 0.1 dB
<b>DC ACCURACY</b>			
Resolution	12+Sign	Bits	
Integral Nonlinearity <sup>2</sup>	$\pm 1.5$	LSB max	
Differential Nonlinearity <sup>2</sup>	$\pm 0.95$	LSB max	Guaranteed No Missing Codes to 13-Bits
Offset Error <sup>3</sup>	$\pm 8$	LSB max	Unipolar Range with Straight Binary output coding
Offset Error Match <sup>2</sup>	$\pm 0.5$	LSB max	
Gain Error <sup>2</sup>	$\pm 6$	LSB max	
Gain Error Match <sup>2</sup>	$\pm 0.6$	LSB max	
Positive Full-Scale Error <sup>2</sup>	$\pm 3$	LSB max	Bipolar Range with Twos Complement Output Coding
Positive Full Scale Error Match <sup>2</sup>	$\pm 0.6$	LSB max	
Bipolar Zero Error <sup>2</sup>	$\pm 8$	LSB max	
Bipolar Zero Error Match <sup>2</sup>	$\pm 0.5$	LSB max	
Negative Full Scale Error <sup>2</sup>	$\pm 4$	LSB max	
Negative Full Scale Error Match <sup>2</sup>	$\pm 0.5$	LSB max	
<b>ANALOG INPUT</b>			
Input Voltage Ranges	$\pm 10$	V	See Table 6 $V_{DD} = +10V$ min, $V_{SS} = -10V$ min, $V_{CC} = 2.7V$ to $5.25V$
(Programmed via Range Register)	$\pm 5$	V	$V_{DD} = +5V$ min, $V_{SS} = -5V$ min, $V_{CC} = 2.7V$ to $5.25V$
	$\pm 2.5$	V	$V_{DD} = +5V$ min, $V_{SS} = -5V$ min, $V_{CC} = 2.7V$ to $5.25V$
	0 to 10	V	$V_{DD} = +10V$ min, $V_{SS} = 0$ V min, $V_{CC} = 2.7V$ to $5.25V$
DC Leakage Current	$\pm 10$	nA max	
Input Capacitance	13.5	pF typ	When in Track, $\pm 10V$ Range
	16.5	pF typ	When in Track, $\pm 5V$ , 0 to 10V Range
	21.5	pF typ	When in Track, $\pm 2.5V$ Range
	3	pF typ	When in Hold
<b>REFERENCE INPUT/OUTPUT</b>			
Input Voltage Range	+2.5 to +3	V min to max	
Input DC Leakage Current	$\pm 1$	$\mu A$ max	
Input Capacitance	20	pF typ	
Reference Output Voltage	2.49/2.51	Vmin/max	
Reference Temperature Coefficient	25	ppm/ $^{\circ}C$ max	
	10	ppm/ $^{\circ}C$ typ	
Reference Output Impedance	25	$\Omega$ typ	

Parameter	Specification	Units	Test Conditions/Comments
<b>LOGIC INPUTS</b>			
Input High Voltage, $V_{INH}$	2.4	V min	$V_{CC} = 4.75$ to $5.25$ V $V_{CC} = 2.7$ to $3.6$ V $V_{IN} = 0V$ or $V_{CC}$
Input High Voltage, $V_{INL}$	0.8	V max	
Input Current, $I_{IN}$	0.4	V max	
Input Capacitance, $C_{IN}^3$	$\pm 1$	$\mu A$ max	
	10	pF max	
<b>LOGIC OUTPUTS</b>			
Output High Voltage, $V_{OH}$	$V_{DRIVE} - 0.2V$	V min	$I_{SOURCE} = 200 \mu A$ $I_{SINK} = 200 \mu A$
Output Low Voltage, $V_{OL}$	0.4	V max	
Floating State Leakage Current	$\pm 1$	$\mu A$ max	Coding bit set to 1 in Control Register  Coding bit set to 0 in Control Register
Floating State Output Capacitance <sup>3</sup>	10	pF max	
Output Coding	Straight Natural Binary Two's Complement		
<b>CONVERSION RATE</b>			
Conversion Time	1.6	$\mu s$ max	16 SCLK Cycles with SCLK = 10 Mhz Sine Wave Input Full Scale Step input See Serial Interface section
Track-and-Hold Acquisition Time	520	ns min	
	520	ns min	
Throughput Rate	500	kSPS max	
<b>POWER REQUIREMENTS</b>			
$V_{DD}^4$	+12V/+16.5V	V min/max	Digital Inputs = 0V or $V_{DRIVE}$ See Table 6
$V_{SS}^4$	-12V/-16.5V	V min/max	See Table 6
$V_{CC}$	+2.7V/+5.25V	V min/max	See Table 6
$V_{DRIVE}$	+2.7V/+5.25V	V min/max	
<b>Normal Mode</b>			
$I_{DD}$	300	$\mu A$ max	$V_{DD} = +16.5V$ $V_{SS} = -16.5V$ $V_{CC} = +5.25V$ $F_{SAMPLE} = TBD$
$I_{SS}$	370	$\mu A$ max	
$I_{CC}$	2	mA max	
<b>Auto-Standby Mode</b>			
$I_{DD}$	TBD	$\mu A$ max	$F_{SAMPLE} = TBD$
$I_{SS}$	TBD	$\mu A$ max	
$I_{CC}$	1.6	mA typ	
<b>Auto-Standby Mode</b>			
$I_{DD}$	TBD	$\mu A$ max	$F_{SAMPLE} = TBD$
$I_{SS}$	TBD	$\mu A$ max	
$I_{CC}$	1	mA typ	
<b>Full Shutdown Mode</b>			
$I_{DD}$	0.9	$\mu A$ max	SCLK On or Off
$I_{SS}$	0.9	$\mu A$ max	
$I_{CC}$	0.9	$\mu A$ max	
<b>POWER DISSIPATION</b>			
<b>Normal Mode</b>			
	26	mW max	$V_{DD} = +16.5V$ , $V_{SS} = -16.5V$ , $V_{CC} = +5.25V$ , $V_{DD} = +5V$ , $V_{SS} = -5V$ , $V_{CC} = +5V$ , $V_{DD} = +16.5V$ , $V_{SS} = -16.5V$ , $V_{CC} = +5.25V$ ,
	12	mW typ	
	35	$\mu W$ max	
<b>Full Shutdown Mode</b>			

## NOTES

<sup>1</sup> Temperature ranges as follows: -40°C to +85°C<sup>2</sup> See Terminology<sup>3</sup> Guaranteed by Characterization<sup>4</sup> Functional from  $V_{DD} = +4.75V$  and  $V_{SS} = -4.75V$ .  
Specifications subject to change without notice.

**TIMING SPECIFICATIONS**

Table 3. Unless otherwise noted,  $V_{DD} = +12V$  to  $+16.5V$ ,  $V_{SS} = -12V$  to  $-16.5V$ ,  $V_{CC} = 2.7V$  to  $5.25$ ,  $V_{DRIVE} = 2.7V$  to  $5.25$ ,  $V_{REF} = 2.5V$  Internal/External,  $T_A = T_{MAX}$  to  $T_{MIN}$

Parameter	Limit at $T_{MIN}$ , $T_{MAX}$	Unit	Description
$f_{SCLK}$	20	kHz min	
	10	MHz max	
$t_{CONVERT}$	$16 \times t_{SCLK}$	ns max	$T_{SCLK} = 1/f_{SCLK}$
$t_{QUIET}$	50	ns max	Minimum Time between End of Serial Read and Next Falling Edge of $\overline{CS}$
$t_1$	10	ns min	Minimum $\overline{CS}$ Pulse width
$t_2$	10	ns min	$\overline{CS}$ to SCLK Setup Time
$t_3$	20	ns max	Delay from $\overline{CS}$ until $D_{OUT}$ Three-State Disabled
$t_4$	TBD	ns max	Data Access Time after SCLK Falling Edge.
$t_5$	$0.4t_{SCLK}$	ns min	SCLK Low Pulsewidth
$t_6$	$0.4t_{SCLK}$	ns min	SCLK High Pulsewidth
$T_7$	10	ns min	SCLK to Data Valid Hold Time
$T_8$	25	ns max	SCLK Falling Edge to $D_{OUT}$ High Impedance
	10	ns min	SCLK Falling Edge to $D_{OUT}$ High Impedance
$T_9$	TBD	ns min	DIN set-up time prior to SCLK falling edge
$T_{10}$	5	ns min	DIN hold time after SCLK falling edge
$T_{POWERUP}$	1	$\mu s$ max	Power up from Auto Standby
	TBD	$\mu s$ max	Power up from Full Shutdown/Auto Shutdown Mode

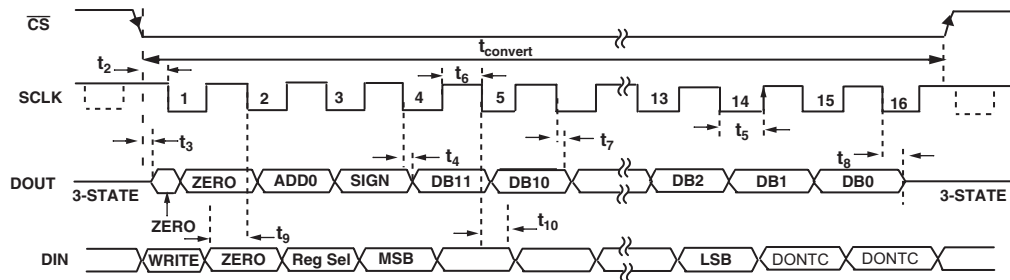

Figure 2. Serial Interface timing Diagram

## ABSOLUTE MAXIMUM RATINGS

Table 4.  $T_A = 25^\circ\text{C}$ , unless otherwise noted

$V_{DD}$ to AGND, DGND	-0.3 V to +16.5 V
$V_{SS}$ to AGND, DGND	+0.3 V to -16.5 V
$V_{CC}$ to AGND, DGND	-0.3V to +7V
$V_{DRIVE}$ to $V_{CC}$	-0.3 V to $V_{CC} + 0.3\text{V}$
$V_{DD}$ to $V_{CC}$	$V_{CC} - 0.3\text{V}$ to +16.5V
AGND to DGND	-0.3 V to +0.3 V
Analog Input Voltage to AGND	$V_{SS} - 0.3\text{V}$ to $V_{DD} + 0.3\text{V}$
Digital Input Voltage to DGND	-0.3 V to +7 V
Digital Output Voltage to GND	-0.3 V to $V_{DRIVE} + 0.3\text{V}$
$REF_{IN}$ to AGND	-0.3 V to $V_{CC} + 0.3\text{V}$
Input Current to Any Pin Except Supplies <sup>1</sup>	$\pm 10\text{mA}$
Operating Temperature Range	$-40^\circ\text{C}$ to $+85^\circ\text{C}$
Storage Temperature Range	$-65^\circ\text{C}$ to $+150^\circ\text{C}$
Junction Temperature	$+150^\circ\text{C}$
TSSOP Package	
$\theta_{JA}$ Thermal Impedance	143 $^\circ\text{C}/\text{W}$
$\theta_{JC}$ Thermal Impedance	45 $^\circ\text{C}/\text{W}$
Pb-free Temperature, Soldering	
Reflow	260(+0) $^\circ\text{C}$
ESD	TBD

<sup>1</sup>Transient currents of up to 100 mA will not cause SCR latch-up.

Stresses above those listed under Absolute Maximum Ratings may cause permanent damage to the device. This is a stress rating only; functional operation of the device at these or any other conditions above those listed in the operational sections of this specification is not implied. Exposure to absolute maximum rating conditions for extended periods may affect device reliability.

## PIN FUNCTIONAL DESCRIPTIONS

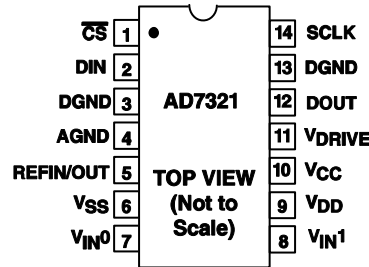

Figure 3. AD7321 Pin Configuration TSSOP

Table 5. AD7321 Pin Function Descriptions

Pin Mnemonic	Pin Number	Description
SCLK	14	Serial Clock. Logic Input. A serial clock input provides the SCLK used for accessing the data from the AD7321. This clock is also used as the clock source for the conversion process.
DOUT	12	Serial Data Output. The conversion output data is supplied to this pin as a serial data stream. The bits are clocked out on the falling edge of the SCLK input and 16 SCLKs are required to access the data. The data stream consists of two leading zeros, one channel identification bit, a Sign bit followed by 12 bits of conversion data. The data is provided MSB first. See the Serial interface section.
$\overline{\text{CS}}$	1	Chip Select. Active low logic input. This input provides the dual function of initiating conversions on the AD7321 and frames the serial data transfer.
DIN	2	Data In. Data to be written to the on-chip registers is provided on this input and is clocked into the register on the falling edge of SCLK. See Register section.
AGND	4	Analog Ground. Ground reference point for all analog circuitry on the AD7321. All analog input signals and any external reference signal should be referred to this AGND voltage.
REF IN/REF <sub>OUT</sub>	5	Reference Input/ Reference Output pin. When enabled the on-chip reference is available on this pin for use external to the AD7321. Alternatively, the internal reference can be disabled and an external reference applied to this input. When using the AD7321 with an external reference, the internal reference must be disabled via the control register. The nominal reference voltage is 2.5 V, which appears at the pin. The default on power up is for external Reference operation. A 470 nF decoupling capacitor should be placed on the Reference pin.
V <sub>CC</sub>	10	Analog Supply Voltage, 2.7 V to 5.25 V. This is the supply voltage for the ADC core on the AD7321. This supply should be decoupled to AGND.
V <sub>DD</sub>	9	Positive power supply voltage. This is the positive supply voltage for the Analog Input section.
V <sub>SS</sub>	6	Negative power supply voltage. This is the negative supply voltage for the Analog Input section.
DGND	3,13	This is the Digital Ground pin.
V <sub>DRIVE</sub>	11	Logic Power Supply input. The voltage applied to this pin determines the operating voltage of the serial interface.
Vin0-Vin1	7,8	Analog input 0 through Analog Input 1. The analog inputs are multiplexed into the on-chip track-and-hold. The analog input channel for conversion is selected by programming the channel address bit ADD0, in the control register. The inputs can be configured as 2 Single-Ended Inputs, 1 True Differential Input pair, 1 Pseudo Differential inputs. The configuration of the Analog inputs is selected by programming the Mode bits, Mode1 and Mode0, in the Control Register. The input range on each input channel is controlled by programming the range register. Input ranges of $\pm 10\text{V}$ , $\pm 5\text{V}$ , $\pm 2.5\text{V}$ and 0 to 10V can be selected on each analog input channel. See AD7321 Registers section.

## TERMINOLOGY

### Differential Nonlinearity

This is the difference between the measured and the ideal 1 LSB change between any two adjacent codes in the ADC.

### Integral Nonlinearity

This is the maximum deviation from a straight line passing through the endpoints of the ADC transfer function. The endpoints of the transfer function are zero scale, a point 1 LSB below the first code transition, and full scale, a point 1 LSB above the last code transition.

### Offset Code Error

This applies to Straight Binary output coding. It is the deviation of the first code transition (00...000) to (00...001) from the ideal, i.e., AGND + 1 LSB.

### Offset Error Match

This is the difference in Offset Error between any two input channels.

### Gain Error

This applies to Straight Binary output coding. It is the deviation of the last code transition (111...110) to (111...111) from the ideal (i.e.,  $4 \times V_{REF} - 1 \text{ LSB}$ ,  $2 \times V_{REF} - 1 \text{ LSB}$ ,  $V_{REF} - 1 \text{ LSB}$ ) after the offset error has been adjusted out.

### Gain Error Match

This is the difference in Gain Error between any two input channels.

### Bipolar Zero Code Error

This applies when using twos complement output coding and a bipolar Analog Input. It is the deviation of the midscale transition (all 1s to all 0s) from the ideal  $V_{IN}$  voltage, i.e., AGND - 1 LSB.

### Bipolar Zero Code Error Match

This refers to the difference in Bipolar Zero Code Error between any two input channels.

### Positive Full Scale Error

This applies when using twos complement output coding and any of the bipolar Analog Input ranges. It is the deviation of the last code transition (011...110) to (011...111) from the ideal ( $+4 \times V_{REF} - 1 \text{ LSB}$ ,  $+2 \times V_{REF} - 1 \text{ LSB}$ ,  $+V_{REF} - 1 \text{ LSB}$ ) after the bipolar Zero Code Error has been adjusted out.

### Positive Full Scale Error Match

This is the difference in Positive Full Scale error between any two input channels.

### Negative Full Scale Error

This applies when using twos complement output coding and any of the bipolar Analog Input ranges. This is the deviation of the first code transition (10...000) to (10...001) from the ideal

(i.e.,  $-4 \times V_{REF} + 1 \text{ LSB}$ ,  $-2 \times V_{REF} + 1 \text{ LSB}$ ,  $-V_{REF} + 1 \text{ LSB}$ ) after the Bipolar Zero Code Error has been adjusted out.

### Negative Full Scale Error Match

This is the difference in Negative Full Scale error between any two input channels.

### Track-and-Hold Acquisition Time

The track-and-hold amplifier returns into track mode after the fifteenth SCLK falling edge. Track-and-hold acquisition time is the time required for the output of the track-and-hold amplifier to reach its final value, within  $\pm 1/2 \text{ LSB}$ , after the end of conversion.

### Signal to (Noise + Distortion) Ratio

This is the measured ratio of signal to (noise + distortion) at the output of the A/D converter. The signal is the rms amplitude of the fundamental. Noise is the sum of all non-fundamental signals up to half the sampling frequency ( $f_s/2$ ), excluding dc. The ratio is dependent on the number of quantization levels in the digitization process; the more levels, the smaller the quantization noise. The theoretical signal to (noise + distortion) ratio for an ideal N-bit converter with a sine wave input is given by:

$$\text{Signal to (Noise + Distortion)} = (6.02N + 1.76) \text{ dB}$$

Thus for a 13-bit converter, this is 80.02 dB.

### Total Harmonic Distortion

Total harmonic distortion (THD) is the ratio of the rms sum of harmonics to the fundamental. For the AD7321 it is defined as:

$$\text{THD}(dB) = 20 \log \frac{\sqrt{V_2^2 + V_3^2 + V_4^2 + V_5^2 + V_6^2}}{V_1}$$

where  $V_1$  is the rms amplitude of the fundamental and  $V_2, V_3, V_4, V_5$  and  $V_6$  are the rms amplitudes of the second through the sixth harmonics.

### Peak Harmonic or Spurious Noise

Peak harmonic or spurious noise is defined as the ratio of the rms value of the next largest component in the ADC output spectrum (up to  $f_s/2$  and excluding dc) to the rms value of the fundamental. Normally, the value of this specification is determined by the largest harmonic in the spectrum, but for ADCs where the harmonics are buried in the noise floor, it will be a noise peak.

### Channel-to-Channel Isolation

Channel-to-channel isolation is a measure of the level of crosstalk between any two channels when operating in the  $\pm 10 \text{ V}$  Range. It is measured by applying a full-scale, 150 kHz sine wave signal to all unselected input channels and determining how much that signal is attenuated in the selected channel with a 50 kHz signal. The figure given is the worst-case across all two



channels for the AD7321. See also Typical Performance Data.

### Intermodulation Distortion

With inputs consisting of sine waves at two frequencies,  $f_a$  and  $f_b$ , any active device with non-linearities will create distortion products at sum and difference frequencies of  $m f_a \pm n f_b$  where  $m, n = 0, 1, 2, 3$ , etc. Intermodulation distortion terms are those for which neither  $m$  nor  $n$  are equal to zero. For example, the second order terms include  $(f_a + f_b)$  and  $(f_a - f_b)$ , while the third order terms include  $(2f_a + f_b)$ ,  $(2f_a - f_b)$ ,  $(f_a + 2f_b)$  and  $(f_a - 2f_b)$ .

The AD7321 is tested using the CCIF standard where two input frequencies near the top end of the input bandwidth are used. In this case, the second order terms are usually distanced in frequency from the original sine waves while the third order terms are usually at a frequency close to the input frequencies. As a result, the second and third order terms are specified separately. The calculation of the intermodulation distortion is as per the THD specification where it is the ratio of the rms sum of the individual distortion products to the rms amplitude of the sum of the fundamentals expressed in dBs.

### PSR (Power Supply Rejection)

Variations in power supply will affect the full-scale transition but not the converter's linearity. Power supply rejection is the maximum change in full-scale transition point due to a change in power supply voltage from the nominal value. See Typical Performance Curves.

## THEORY OF OPERATION

### CIRCUIT INFORMATION

The AD7321 is a fast, 2-Channel, 12-bit plus Sign, Bipolar Input, Serial A/D converter. The AD7321 can accept bipolar input ranges that include  $\pm 10V$ ,  $\pm 5V$ ,  $\pm 2.5V$ . It can also accept a 0 to 10V unipolar input range. A different analog input range can be programmed on each analog input Channel via the on-chip Range register. The AD7321 has a high speed serial interface that can operate at throughput rates up to 500 ksp/s.

The AD7321 requires  $V_{DD}$  and  $V_{SS}$  dual supplies for the high voltage analog input structure. These supplies must be equal to or greater than the analog input range. See Table 6 for the minimum requirements on these supplies for each Analog Input Range. The AD7321 requires a low voltage 2.7V to 5.25 V  $V_{CC}$  supply to power the ADC core.

**Table 6. Reference and Supply Requirements for each Analog Input Range**

Selected Analog Input Range (V)	Reference Voltage (V)	Full Scale Input Range(V)	$AV_{CC}$ (V)	Minimum $V_{DD}/V_{SS}$ (V)
$\pm 10$	2.5	$\pm 10$	3/5	$\pm 10$
	3.0	$\pm 12$	3/5	$\pm 12$
$\pm 5$	2.5	$\pm 5$	3/5	$\pm 5$
	3.0	$\pm 6$	3/5	$\pm 6$
$\pm 2.5$	2.5	$\pm 2.5$	3/5	$\pm 5$
	3.0	$\pm 3$	3/5	$\pm 5$
0 to 10	2.5	0 to 10	3/5	+10/AGND
	3.0	0 to 12	3/5	+12/AGND

The Analog Inputs can be configured as either 2 Single-Ended inputs, 1 True Differential Inputs, or 1 Pseudo Differential Input. Selection can be made by programming the Mode bits, Mode0 and Mode1, in the on-chip Control Register.

The serial clock input accesses data from the part but also provides the clock source for each successive approximation ADC. The AD7321 has an on-chip 2.5 V reference. If an External Reference is the preferred option the user must write to the reference bit in the control register to disable the internal Reference.

The AD7321 also features power-down options to allow power saving between conversions. The power-down modes are selected by programming the power management bits in the on-chip Control Register, as described in the Modes of Operation section.

### CONVERTER OPERATION

The AD7321 is a successive approximation analog-to-digital converter, based around two capacitive DACs. Figure 4 and Figure 5 show simplified schematics of the ADCs in Single Ended Mode during the acquisition and conversion phase, respectively. Figure 6 and Figure 7 show simplified schematics of the ADC in Differential Mode during acquisition and conversion phase, respectively. The ADC is comprised of control logic, a SAR, and a capacitive DAC. In Figure 4 (the acquisition phase), SW2 is closed and SW1 is in position A, the comparator is held in a balanced condition, and the sampling capacitor array acquires the signal on the input.

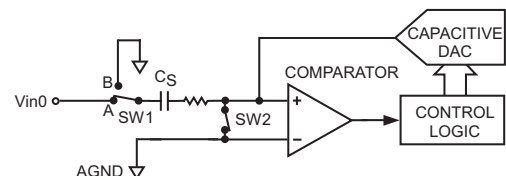

Figure 4. ADC Acquisition Phase(Single Ended)

When the ADC starts a conversion (Figure 5), SW2 will open and SW1 will move to position B, causing the comparator to become unbalanced. The control logic and the charge redistribution DAC is used to add and subtract fixed amounts of charge from the sampling capacitor arrays to bring the comparator back into a balanced condition. When the comparator is rebalanced, the conversion is complete. The Control Logic generates the ADC output code.

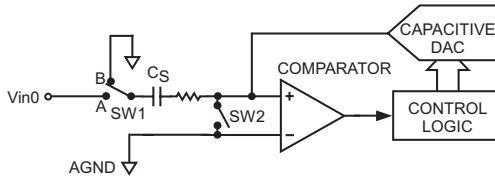

Figure 5. ADC Conversion Phase(Single Ended)

Figure 6 shows the differential configuration during the Acquisition phase. For the Conversion Phase, SW3 will open, SW1 and SW2 will move to position B, see Figure 7. The output impedances of the source driving the Vin+ and Vin- pins must be matched; otherwise the two inputs will have different settling times, resulting in errors.

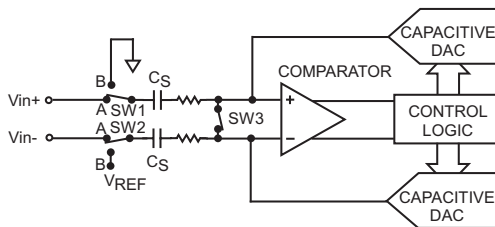

Figure 6. ADC Differential Configuration during Acquisition Phase

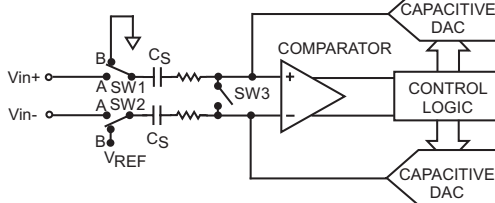

Figure 7. ADC Differential Configuration during Conversion Phase

**Output Coding**

The AD7321 default output coding is set to two's complement. The output coding is controlled by the Coding bit in the Control Register. To change the output coding to Straight Binary Coding the Coding bit in the Control Register must be set. When operating in Sequence mode the output coding for each channel in the sequence will be the value written to the coding bit during the last write to the Control Register.

**Transfer Functions**

The designed code transitions occur at successive integer LSB values (i.e., 1 LSB, 2 LSB, and so on). The LSB size is dependant on the Analog input Range selected.

Table 7. LSB sizes for each Analog Input Range

Input Range	Full Scale Range/8192	LSB Size
±10V	20V/8192	2.441 mV
±5V	10V/8192	1.22 mV
±2.5V	5V/8192	0.61 mV
0 to 10V	10V/8192	1.22 mV

The ideal transfer characteristic for the AD7321 when Twos Complement coding is selected is shown in Figure 8, and the ideal transfer characteristic for the AD7321 when Straight Binary coding is selected is shown in Figure 9.

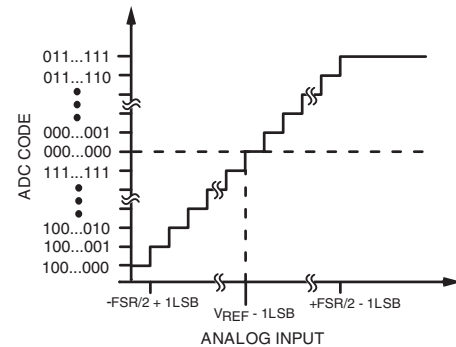

Figure 8. Twos Complement Transfer Characteristic (Bipolar Ranges)

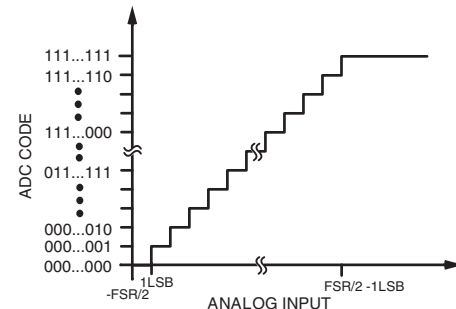

Figure 9. Straight Binary Transfer Characteristic (Bipolar Ranges)

**ANALOG INPUT**

The analog inputs of the AD7321 may be configured as Single-Ended, True differential or Pseudo Differential via the Control Register Mode Bits as shown in Table 10 of the Register Section. The AD7321 can accept True bipolar input signals. On power up the Analog inputs will operate as 2 Single-Ended Analog Input Channels. If True Differential or Pseudo Differential is required, a write to the Control register is necessary to change this configuration after power up.

Figure 10 shows the equivalent Analog input circuit of the AD7321 in Single-Ended Mode. Figure 11 shows the equivalent Analog input structure in Differential mode. The Two Diodes

provide ESD protection for the Analog Inputs.

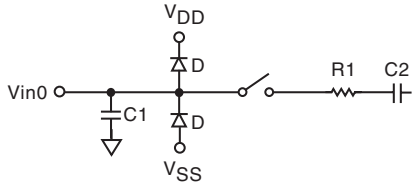

Figure 10. Equivalent Analog Input Circuit-(Single Ended)

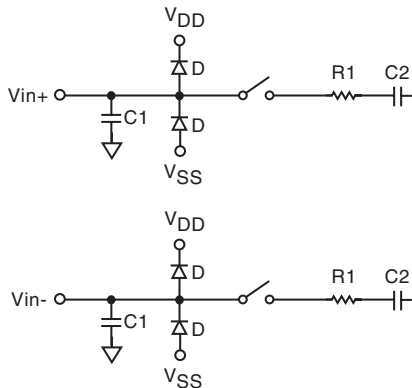

Figure 11. Equivalent Analog Input Circuit-(Differential)

Care should be taken to ensure the Analog Input never exceeds the  $V_{DD}$  and  $V_{SS}$  supply rails by more than 300 mV. This will cause the diodes to become forward biased and start conducting into either the  $V_{DD}$  or  $V_{SS}$  rails. These diodes can conduct up to 10 mA without causing irreversible damage to the part.

The Capacitor C1, in Figure 10 and Figure 11 is typically 4 pF and can primarily be attributed to pin capacitance. The resistor R1, is a lumped component made up of the on-resistance of the input multiplexer and the track-and-hold switch. The Capacitor C2, is the sampling capacitor, its capacitance will vary depending on the Analog input range selected.

**Track-and-Hold Section**

The Track-and-Hold on the Analog Input of the AD7321 allows the ADC to accurately convert an input sine wave of full scale amplitude to 13-Bit accuracy. The input bandwidth of the Track-and-Hold is greater than the Nyquist rate of the ADC, the AD7321 can handle frequencies up to 7 MHz.

The Track-and-Hold enters its tracking mode on the 14<sup>th</sup> SCLK rising edge after the  $\overline{CS}$  falling edge. The time required to acquire an input signal will depend on how quickly the sampling capacitor is charged. With zero source impedance 250 ns will be sufficient to acquire the signal to the 13-bit level.

The acquisition time required is calculated using the following formula:

$$t_{ACQ} = 10 \times ((R_{SOURCE} + R) C)$$

where C is the Sampling Capacitance and R is the resistance seen by the track-and-hold amplifier looking back on the input. For the AD7321, the value of R will include the on-resistance of the input multiplexer. The value of R is typically 300  $\Omega$ .  $R_{SOURCE}$  should include any extra source impedance on the Analog input.

**TYPICAL CONNECTION DIAGRAM**

Figure 12 shows a typical connection diagram for the AD7321. In this configuration the AGND pin is connected to the Analog ground plane of the system. The DGND pin is connected to the Digital ground plane of the system. The Analog Inputs on the AD7321 can be configured to operate in Single Ended, True Differential or Pseudo Differential Mode. The AD7321 can operate with either the internal or an external reference. In Figure 12, the AD7321 is configured to operate with the internal 2.5V reference. A 470 nF decoupling capacitor is required when operating with the internal reference.

The  $V_{CC}$  pin can be connected to either a 3V or a 5V supply voltage. The  $V_{DD}$  and  $V_{SS}$  are the dual supplies for the high voltage analog input structures. The voltage on these pins must be equal to or greater than the highest analog input range selected on the analog input channels, see Table 6 for more information. The  $V_{DRIVE}$  pin is connected to the supply voltage of the microprocessor. The voltage applied to the  $V_{DRIVE}$  input controls the voltage at which the serial interface operates.

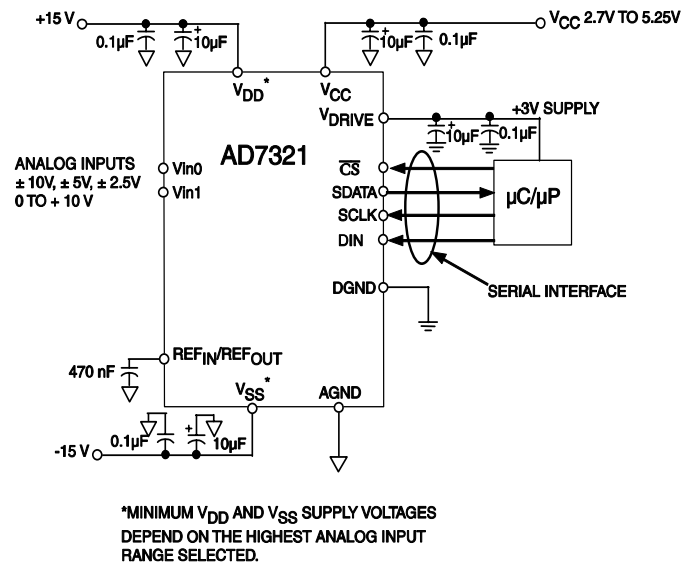

\*MINIMUM  $V_{DD}$  AND  $V_{SS}$  SUPPLY VOLTAGES DEPEND ON THE HIGHEST ANALOG INPUT RANGE SELECTED.

Figure 12. Typical Connection Diagram

## AD7321 REGISTERS

The AD7321 has two-programmable registers, the **Control Register** and the **Range Register**. These registers are write only registers.

### Addressing these Registers

A serial transfer on the AD7321 consists of 16 SCLK cycles. The three MSBs on the DIN line during each 16 SCLK transfer are decoded to determine which register is addressed. The three MSBs consists of the Write bit, ZERO bit and a Register Select bit. The Register Select bit is used to determine which of the Two on-board registers is selected. The Write bit will determine if the Data on the DIN line following the Register select bit is loaded into the addressed register or not. If the Write bit is 1 the bits will be loaded into the register addressed by the Register Select bit. If the Write Bit is a 0 the data on the DIN will not be loaded into any register and both registers will remain unchanged.

**Table 8. Decoding Register Select bit and Write bit.**

Write	ZERO	Register Select	Comment
0	0	0	Data on the DIN line during this serial transfer will be ignored. Register contents will remain unchanged.
1	0	0	This combination selects the Control Register. The subsequent 12 bits will be loaded into the Control Register.
1	0	1	This combination selects the Range Register. The subsequent 8 bits will be loaded into the Range Register.

### CONTROL REGISTER

The Control Register is used to select the Analog Input configuration, Reference, Coding, Power mode etc. The Control Register is a write only 12-bit register. Data loaded on the DIN line corresponds to the AD7321 configuration for the next conversion. Data should be loaded into the Control Register after the Range Register has been initialized. The bit functions of the Control Register are outlined in Table 9.

#### Control Register (The Power-up status of all bits is 0)

**Table 9. Control Register**

**MSB** **LSB**

Write	ZERO	Register Select	ZERO	ZERO	ADD0	Mode1	Mode0	PM1	PM0	Coding	Ref	Seq1	Seq2	ZERO	0
-------	------	-----------------	------	------	------	-------	-------	-----	-----	--------	-----	------	------	------	---

Bit	Mnemonic	Comment
10	ADD0	This Channel Address bit is used to select the analog input channel for the next conversion if the Sequencer is not being used.
9, 8	Mode1, Mode0	These two mode bits are used to select the configuration on the two analog Input Pins. They are used in conjunction with the channel Address bit. On the AD7321 the analog inputs can be configured as either 2 Single Ended Inputs, 1 Fully Differential Input, 1 Pseudo Differential input. See Table 10.
7,6	PM1, PM0	Power Management Bits. These two bits are used to select different power mode options on the AD7321. See Table 11.
5	Coding	This bit is used to select the type of output coding the AD7321 will use for the next conversion result. If the Coding = 0 then the output coding will be 2s Complement. If Coding = 1, then the output coding will be Straight Binary. When operating in Sequence mode the output coding for each channel will be the value written to the coding bit during the last write to the Control Register.

4	Ref	Reference bit. This bit is used to enable or disable the internal reference. If this Ref = 0 then the External Reference will be enabled and used for the next conversion and the internal reference will be disabled. If Ref = 1 then the Internal Reference will be used for the next conversion. When operating in Sequence mode the Reference used for each channel will be the value written to the Ref bit during the last write to the Control Register.
3,2	Seq1/Seq2	The Sequence 1 and Sequence 2 bits are used to control the operation of the Sequencer. See Table 12
14,12,11,1	ZERO	A zero must be written to this bit to ensure correct operation of the AD7321.

Table 10. Analog Input Configuration Selection

Channel Address Bit	Mode1 = 1, Mode0 = 1	Mode1 = 1, Mode0 = 0	Mode1 = 0, Mode0 = 1	Mode1 = 0, Mode0 = 0	
	1 Pseudo Differential i/p	1 Fully Differential i/p	Not Allowed	Two-Single Ended i/ps	
	<b>ADD0</b>	<b>Vin+</b>	<b>Vin-</b>	<b>Vin+</b>	<b>Vin-</b>
	0	Vin0	Vin1	Vin0	Vin1
	1	Vin0	Vin1	Vin0	Vin1
				Vin0	AGND
				Vin1	AGND

Table 11. Power Mode Selection

PM1	PM0	Description
1	1	<b>Full Shutdown Mode</b> , In this mode all internal circuitry on the AD7321 is powered down. Information in the Control register is retained when the AD7321 is in Full Shutdown Mode.
1	0	<b>Auto Shutdown Mode</b> , The AD7321 will enter Full Shut down at the end of each conversion when the control register is updated. All internal circuitry is powered down in Full Shutdown.
0	1	<b>Auto Standby Mode</b> , In this mode all internal circuitry is powered down excluding the internal Reference. The AD7321 will enter Auto Standby Mode at the end of the Conversion after the control register is updated.
0	0	<b>Normal Mode</b> , All internal Circuitry is powered up at all times.

Table 12. Sequencer Selection

Seq1	Seq2	Sequence type
0	0	The Channel Sequencer is not used. The Analog Channel selected by programming the ADD0 bit in the Control Register selects the next channel for conversion.
1	0	This Configuration is used in conjunction with the Channel Address Bit in the Control Register. Provided that the channel Address bit is 1, the ADC will convert firstly on channel 0 then channel 1 and will repeat this sequence until the Seq bits are changed in the Control Register.
1	1	The Channel Sequencer is not used. The Analog Channel selected by programming the ADD0 bit in the Control Register selects the next channel for conversion.

**RANGE REGISTER**

The Range register is used to select one Analog input Range per Analog input channel. It is a 6-Bit write only Register, with two dedicated Range bits for each of the two Analog Input Channels. There are four Analog input Ranges to choose from,  $\pm 10V$ ,  $\pm 5V$ ,  $\pm 2.5V$ , 0 to 10V. A write to the Range Register is selected by setting the Write bit to 1 and the Register Select bit to 1. Once the initial write to the Range Register occurs the AD7321 automatically configures the two Analog inputs to the appropriate range, as indicated by the Range register, each time any one of these analog input channels is selected. The  $\pm 10V$  input Range is selected by default on each analog input channel. See Table 13. When writing the 16-bit word to the Range register the unused LSBs should be zeros as shown in Table 13.

**Table 13. Range Register**

Write	Zero	Register Select	Vin0A	Vin0B	0	0	Vin1A	Vin1B	0	0	0	0	0	0	0
-------	------	-----------------	-------	-------	---	---	-------	-------	---	---	---	---	---	---	---

VinXA	VinXB	Description
0	0	This combination selects the $\pm 10V$ Input Range on Analog Input X.
0	1	This combination selects the $\pm 5V$ Input Range on Analog Input X.
1	0	This combination selects the $\pm 2.5V$ Input Range on Analog Input X.
1	1	This combination selects the 0 to 10V Input Range on Analog Input X.

**REFERENCE**

The AD7321 can operate with either the internal 2.5V on-chip reference or an externally applied reference. The internal reference is selected by setting the REF bit in the Control Register to 1. On power up the REF bit will be 0, selecting the external Reference for the AD7321 conversion. For external reference operation the REF<sub>IN</sub>/REF<sub>OUT</sub> pin should be decoupled to AGND with a 470 nF capacitor.

The internal Reference circuitry consists of a 2.5V band gap reference and a reference buffer. When operating the AD7321 in internal Reference mode the 2.5V internal reference is available at the REF<sub>IN</sub>/REF<sub>OUT</sub> pin. When using the AD7321 with the internal reference the REF<sub>IN</sub>/REF<sub>OUT</sub> pin should be decoupled to AGND using a 470 nF cap. It is recommended that the Internal Reference be buffered before applying it elsewhere in the system.

The AD7321 is specified for a 2.5V to 3V reference range. When a 3V reference is selected the ranges will be,  $\pm 12V$ ,  $\pm 6V$ ,  $\pm 3V$  and 0 to 12V. For these ranges the V<sub>DD</sub> and V<sub>SS</sub> supply must be equal to or greater than the max Analog Input Range selected.

On power up if the internal reference operation is required for the ADC conversion, a write to the control register is necessary to set the REF bit to 1. During the Control Register write the conversion result from the first initial conversion will be invalid. The reference buffer will require TBD us to power up and charge the 470 nF decoupling cap, during the power up time the conversion result from the ADC will be invalid.

## MODES OF OPERATION

The AD7321 has a number of different modes of operation. These modes are designed to provide flexible power management options. These options can be chosen to optimize the power dissipation/throughput rate ratio for the differing application requirements. The mode of operation of the AD7321 is controlled by the Power Management bits, PM1 and PM0, in the Control register as detailed in

Table 11. The default mode is Normal Mode, where all internal circuitry is fully powered up.

### Normal Mode (PM1 = PM0 = 0)

This mode is intended for the fastest throughput rate performance, the AD7321 is fully powered up at all times. Figure 13 shows the general diagram of operation of the AD7321 in Normal Mode.

The Conversion is initiated on the falling edge of  $\overline{CS}$  and the track and hold will enter hold mode as described in the Serial Interface Section. The Data on the DIN line during the 16 SCLK transfer will be loaded into one of the on-chip registers, provided the Write bit is set. The register is selected by programming the Register select bits, see Table 1 of the Register section.

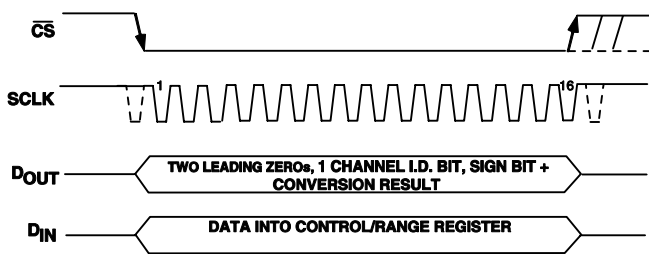

Figure 13. Normal Mode

The AD7321 will remain fully powered up at the end of the conversion provided both PM1 and PM0 contain 0 in the control Register.

Sixteen serial clock cycles are required to complete the conversion and access the conversion result. At the end of the conversion  $\overline{CS}$  may idle high until the next conversion or may idle low until sometime prior to the next conversion.

Once the data transfer is complete, another conversion can be initiated after the quiet time,  $t_{\text{QUIET}}$ , has elapsed.

### Full Shutdown Mode (PM1 = PM0 = 1)

In this mode all internal circuitry on the AD7321 is powered down. The part retains information in the Registers during Full Shut down. The AD7321 remains in Full shutdown mode until the power managements bits in the Control Register, PM1 and PM0, are changed.

If a write to the control register occurs while the part is in Full Shut down mode, with the power management bits, PM1 and PM0 set to 0, normal mode, the part will begin to power up on the  $\overline{CS}$  rising edge.

To ensure the AD7321 is fully powered up,  $t_{\text{POWER UP}}$ , should elapse before the next  $\overline{CS}$  falling edge.

### Auto Shutdown Mode (PM1 = 1, PM0 = 0)

Once the Auto Shutdown mode is selected the AD7321 will automatically enter shutdown at the end of each conversion. The AD7321 retains information in the registers during Shutdown. The track-and-hold is in hold during shutdown. On the falling  $\overline{CS}$  edge, the track-and-hold that was in hold during shutdown will return to track.

The power-up from Auto Shutdown is TBD  $\mu\text{s}$

In this mode the power consumption of the AD7321 is greatly reduced with the part entering shutdown at the end of each conversion. When the control register is programmed to move into Auto Shutdown mode, it does so at the end of the conversion.

### Auto Standby Mode (PM1 = 0, PM0 = 1)

In Auto Standby mode portions of the AD7321 are powered down but the on-chip reference remains powered up. The reference bit in the Control register should be 0 to ensure the on-chip reference is enabled. This mode is similar to Auto Shutdown but allows the AD7321 to power up much faster, allowing faster throughput rates to be achieved.

The AD7321 will enter standby at the end of the conversion. The part retains information in the Registers during Standby. The AD7321 will remain in standby until it receives a  $\overline{CS}$  falling edge. The ADC will begin to power up on the  $\overline{CS}$  falling edge. On this  $\overline{CS}$  falling edge the track-and-hold that was in hold mode while the part was in Standby will return to track. Wake-up time from Standby is 1  $\mu\text{s}$ . The user should ensure that 1  $\mu\text{s}$  has elapsed before attempting a valid conversion. When running the AD7321 with the maximum 10 Mhz SCLK, one dummy conversion of 16 x SCLKs is sufficient to power up the ADC. This dummy conversion effectively halves the throughput rate of the AD7321, with every second conversion result being a valid result. Once Auto Standby mode is selected, the ADC can move in and out of the low power state by controlling the  $\overline{CS}$  signal.



## SERIAL INTERFACE

Figure 14 shows the timing diagram for the serial interface of the AD7321. The serial clock applied to the SCLK pin provides the conversion clock and also controls the transfer of information to and from the AD7321 during a conversion.

The  $\overline{CS}$  signal initiates the data transfer and the conversion process. The falling edge of  $\overline{CS}$  puts the track-and-hold into hold mode, take the bus out of three-state and the analog input signal is sampled at this point. Once the conversion is initiated it will require 16 SCLK cycles to complete.

The track-and-hold will go back into track on the 14th SCLK rising edge. On the sixteenth SCLK falling edge, the DOUT line will return to three-state. If the rising edge of  $\overline{CS}$  occurs before 16 SCLK cycles have elapsed, the conversion will be terminated, the DOUT line will return to three-state, and depending on

when the  $\overline{CS}$  signal is brought high the addressed register may or may not be updated. Data is clocked into the AD7321 on the SCLK falling edge. The three MSBs on the DIN line are decoded to select which register is being addressed. The Control Register is an eleven bit register, if the control register is addressed by the three MSBs, the data on the DIN line will be loaded into the Control on the 15<sup>th</sup> SCLK falling edge. If the Range register is addressed the data on the DIN line will be loaded into the addressed register on the 11<sup>th</sup> SCLK falling edge.

Conversion data is clocked out of the AD7321 on each SCLK falling edge. Data on the DOUT line will consist of two leading zeros, a channel identifier bit, a Sign bit and the 12-bit conversion result. The channel identifier bit is used to indicate which channel the conversion result corresponds to.

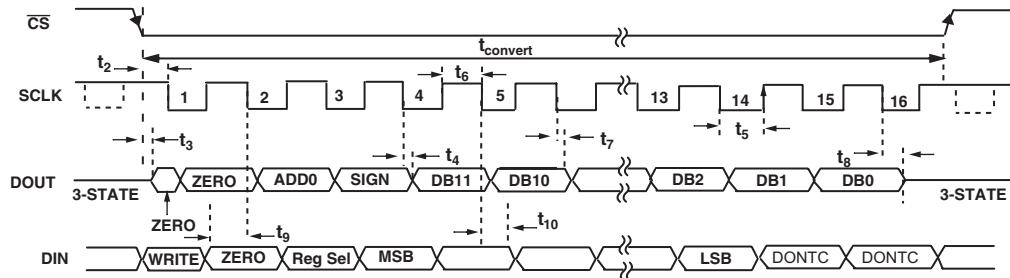
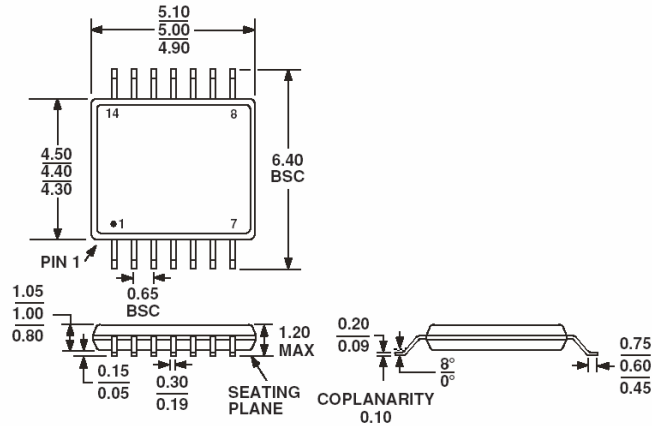

Figure 14. Serial Interface timing Diagram (Control register write)

## OUTLINE DIMENSIONS

14-Lead Thin Shrink Small Outline (TSSOP)  
(RU-14)



COMPLIANT TO JEDEC STANDARDS MO-153AB-1

## Ordering Guide

AD7321 Products	Temperature Package	Package Description	Package Outline
AD7321BRUZ	-40°C to +85°C	TSSOP	RU-14
EVAL-AD7321CB <sup>1</sup>		Evaluation Board	
EVAL-CONTROL BRD <sup>2</sup>		Controller Board	

## NOTES

1 This can be used as a stand-alone evaluation board or in conjunction with the EVAL-CONTROL Board for evaluation/demonstration purposes.

2 This board is a complete unit allowing a PC to control and communicate with all Analog Devices evaluation boards ending in the CB designators. To order a complete evaluation kit, the particular ADC evaluation board, e.g., EVAL-AD7321CB, the EVAL-CONTROL BRD2, and a 12V transformer must be ordered. See relevant Evaluation Board Technical note for more information.

## ESD CAUTION

ESD (electrostatic discharge) sensitive device. Electrostatic charges as high as 4000 V readily accumulate on the human body and test equipment and can discharge without detection. Although this product features proprietary ESD protection circuitry, permanent damage may occur on devices subjected to high energy electrostatic discharges. Therefore, proper ESD precautions are recommended to avoid performance degradation or loss of functionality.

